

SUPRAMOLECULAR POLYMERS

SUPRAMOLEKULARNI POLIMERI

Majda Žigon, Gabriela Ambrožič

National Institute of Chemistry, Hajdrihova 19, SI-1000 Ljubljana, Slovenia
majda.zigon@ki.si

Prejem rokopisa – received: 2003-07-08; sprejem za objavo – accepted for publication: 2003-09-08

In this work supramolecular polymerization and polymers are reviewed. The concepts behind supramolecular chemistry underlie molecular recognition based on the bonding of complementary functional groups of low molar mass compounds or polymers via noncovalent interactions (Coulombic interactions, hydrogen bonding, and van der Waals interactions). Due to the reversibility of noncovalent interactions, these materials are dynamic, capable of undergoing annealing, healing and adaptation processes, which gives supramolecular polymers a major advantage over conventional covalent polymers. By choosing suitable functional groups, as well as the proper type of interaction, a variety of novel supramolecular polymers with tailored properties can be synthesized including functional materials, smart materials, and self-healing materials.

Key words: supramolecular polymer chemistry, supramolecular polymers, noncovalent interactions, side-chain liquid crystalline polymers

V delu podajamo pregled supramolekularne polimerizacije in polimerov. Osnova supramolekularne kemije je postopek molekularnega razpoznavanja, ki temelji na vezavi komplementarnih funkcionalnih skupin nizkomolekularnih spojin ali polimerov z nekovalentnimi interakcijami (Coulombske interakcije, vodikove vezi in van der Waalsove interakcije). Zaradi reverzibilnosti nekovalentnih interakcij so to dinamični materiali, ki lahko sami odpravijo napake v strukturi ali na površini, kar je odločilna prednost v primerjavi s tradicionalnimi kovalentnimi polimeri. Z izbiro primernih funkcionalnih skupin in vrste interakcij lahko tako sintetiziramo nove supramolekularne polimere z načrtovanimi lastnostmi, ki vključujejo funkcionalne in »pametne« materiale ter materiale, ki se po zunanji obremenitvi sami strukturno reorganizirajo v prvotno stanje.

Ključne besede: supramolekularna polimerna kemija, supramolekularni polimeri, nekovalentne interakcije, stranskovertični tekočokristalinični polimeri

1 INTRODUCTION

Synthetic polymeric materials are among the most important classes of new materials to have been introduced in the 20th century and have successfully replaced many traditional materials. The term *polymers* is reserved for macromolecules consisting of a large number of repeating units covalently linked together into long chains. However, it was not until 1927 that Hermann Staudinger through his pioneering work on the solution properties of polymers succeeded in demonstrating that polymers consist of large macromolecules and not of colloidal aggregates of small molecules or particles as was previously believed¹.

Contrary to conventional covalent polymers prepared by the polymerization of low molar mass reactive compounds (monomers), *supramolecular polymers*, sometimes called *polymeric complexes*, are arrays of low or high molar mass molecules reversibly self-assembled through noncovalent interactions². Various types of interactions can be used in the preparation of supramolecular polymers: electrostatic forces, H-bonding, van der Waals interactions, donor-acceptor interactions, metal ion coordination, etc. These interactions are weaker than covalent bonds, which makes supramolecular polymers thermodynamically less stable, kinetically more labile, and dynamically more flexible than covalent polymers. Many examples of supramo-

lecular polymers can be found in nature, such as nucleic acids, polypeptides and polysaccharides: all of which have H-bonding functional groups that play a critical role in biological processes and the formation of supramolecular structures (2 and 3-helical DNA, protein β -sheets, etc.)^{2,3}.

However, the term supramolecular polymer is not used solely for polymer chains consisting of repeating units held together by non-covalent interactions. In a broader sense, it is also used for self-organized macromolecules of conventional polymers utilizing non-covalent interactions to determine their material properties. Some examples of multimolecular self-organization in conventional polymers are polyamides (H-bonding), polyesters (dipole-dipole interaction), or polyethylenes (dispersion interaction). Block copolymers are an example of the self-organization of polymers leading to structured materials⁴. Regularly shaped nanostructures can be prepared e.g. with block copolymers where one type of segment prefers to crystallize, while another type of segment remains in disordered form⁵. Further examples of self-organized polymers are micelles, bilayers, liquid crystalline polymers, etc. This review is focused only on supramolecular polymers prepared by the self-assembly of molecules with complementary functional groups via intermolecular noncovalent interactions.

2 SUPRAMOLECULAR CHEMISTRY AND POLYMER CHEMISTRY

Both the concept and the term *supramolecular chemistry* were introduced in 1978 and led to the implementation of molecular recognition based on the bonding of complementary functional groups^{6,7}. The basis of the molecular recognition process is molecular information 'built into' the receptor and substrate (**Figure 1**). This involves storage of information at the molecular level in terms of structural features using covalent bonds, as well as information retrieval, transfer and processing at the supramolecular level based on specific interactions. Recognition further implies interactional and geometrical complementarity between the associating species. Important characteristics for binding sites are electronic properties (charge, polarity, polarizability), size, shape, number and arrangement in the receptor framework as well as their eventual reactivity. In supramolecular chemistry, one can distinguish two, partially overlapped areas (Figure 1): (a) supermolecules, *i.e.*, well-defined, discrete oligomolecular species that result from the intermolecular association of a few components, and (b) supramolecular assemblies, *i.e.*, polymolecular entities that result from the spontaneous association of a large number of components⁶. These species have more or less well-defined microscopic organization and macroscopic characteristics depending on their nature, e.g. films, layers, membranes, vesicles, micelles, colloids, gels, mesomorphic phases, solid state structures (nanostructured materials), etc².

Supramolecular polymer chemistry, which is the combination of polymer chemistry and supramolecular chemistry, dates back to 1989 when J. M. Lehn and coworkers first succeeded in preparing a supramolecular linear polymer⁸. The preparation of supramolecular polymers made of repeating units joined by noncovalent interactions is schematically shown in **Figure 2**. Chain growth occurs upon mixing complementary monomers in solution or in the molten state. Growth control and regulation of structure and composition can be achieved by means of external factors, such as temperature, pH,

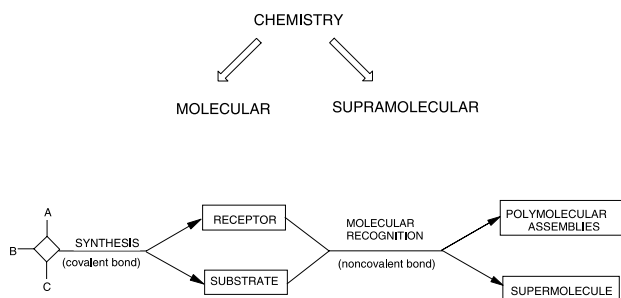

Figure 1: Formation of supermolecules and supramolecular polymers by molecular recognition

Slika 1: Nastanek supermolekul in supramolekularnih polimerov s postopkom molekularnega razpoznavanja

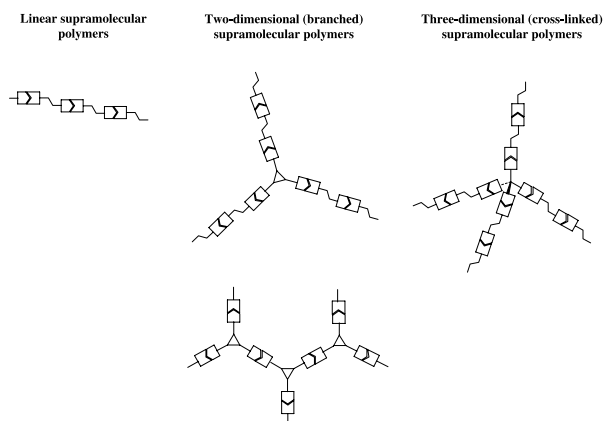

Figure 2: Schematic representation of linear, branched, and cross-linked supramolecular polymers

Slika 2: Shematska predstavitev linearnih, razvejenih in zamreženih supramolekularnih polimerov

metal ions, competing ligands, end-capping units, etc. Supramolecular structures are stabilized by multiple non-covalent interactions, among which a single specific interaction usually plays a dominant role^{2,9-11}.

Coulombic interaction between permanent charges and dipoles may be of the ion-ion (ion pair), ion-dipole or ion-quadrupole type. Attractive interaction occurs between fixed and complementary ionizable groups and is modulated by co- and counter-ions. It is a non-directional interaction, but is the strongest of all non-covalent interactions. *Hydrogen bonding* is an important unidirectional interaction in both synthetic and biological molecules. The H-bond involves a proton donor (C-H, O-H, N-H, F-H) and proton acceptor atom (O, N) with a separation distance of about 3Å. The binding energy of normal H-bonding is between 10 and

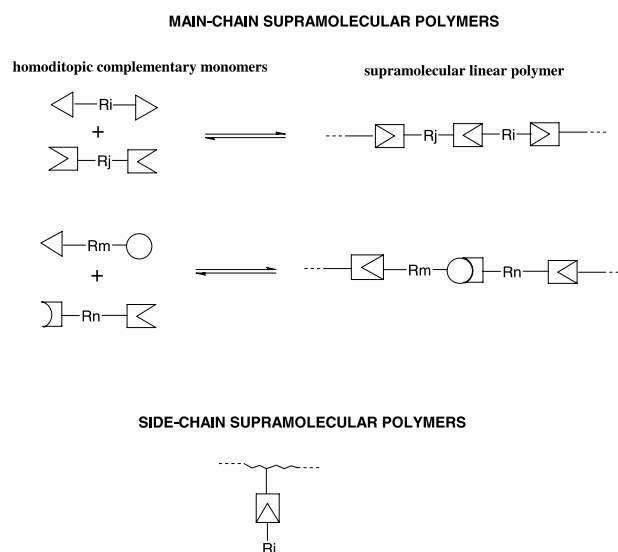

Figure 3: Schematic representation of main-chain and side-chain supramolecular polymers

Slika 3: Shematska predstavitev glavnoverižnih in stransko verižnih supramolekularnih polimerov

50 kJ/mol. *Van der Waals interactions* are the weakest among non-covalent interactions; their binding energy is about (0.1 to 1) kJ/mol. Van der Waals interactions include: induced dipoles, charge transfer (π - π stacking), dispersive or London attractions, and anisotropic attractions^{2,9}.

3 SUPRAMOLECULAR POLYMERS

Supramolecular polymers may be main-chain, side-chain, branched or cross-linked, depending on the number and disposition of the interaction subunits. Main-chain supramolecular polymers may be homopolymers formed from monomers with two identical interaction groups or random copolymers with different interaction groups. Side-chain supramolecular polymers are formed when molecules with a single interaction group are attached to complementary groups on the main chain of a traditional covalent polymer (**Figure 3**). When components for the preparation of supramolecular polymers contain three or more equivalent recognition groups and are mixed with linear associating species then branched (two-dimensional) and three-dimensional or cross-linked (networks, physical gels) supramolecular polymers are obtained (**Figure 2**)³.

According to the type of intermolecular interaction, supramolecular polymers can be divided into different categories. The three main classes are: coordination polymers, polymers by π - π stacking, and H-bonded polymers^{2,9-11}.

Coordination polymers are made of monomeric components usually carrying metal ion binding subunits. These are interesting because of their potential magnetic, electronic, or photonic properties. However, they lack flexibility and thus resemble covalent polymers. The bonds within these polymers can be cleaved by dissolving the polymer in a strongly coordinating solvent¹⁰.

Polymers by π - π stacking or arene-arene interaction are highly ordered polymers that are usually formed in solution. Typical examples are discotic (disc-shaped) liquid crystalline polymers¹¹, which may be generated via the initial formation of dislike supermolecules, where the core usually consists of a planar aromatic system and the side chains are flexible alkyl chains. The

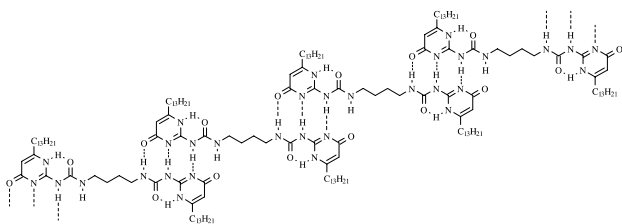

Figure 4: Schematic representation of supramolecular hydrogen-bonded polymers via quadruple H-bonds¹⁴

Slika 4: Shematska predstavitev supramolekularnih polimerov, povezanih s štirimi vodikovimi vezmi¹⁴

interdisc π - π stacking interaction between large aromatic cores is several orders of magnitude larger than the intercolumnar dispersion van der Waals interactions via flexible alkyl side chains. Discotics exhibit relatively poor mechanical properties and high electronic mobility, making them suitable for plastic transistors and photovoltaics. Through the association of several columnar superstructures it is also possible to obtain fibers.

Hydrogen-bonded polymers may possess single or multiple H-bonds¹⁰⁻¹⁵. For example, by using a quadruple H-bonded self-complementary unit (ureidopyrimidone) it was possible to prepare supramolecular polymers (linear¹⁴, networks¹⁵) displaying most of the macroscopic properties of conventional covalent polymers (**Figure 4**).

An important class of supramolecular polymers that self-assemble via H-bonding into well-defined structures are *liquid crystalline (LC) polymers*^{12,16-18}. As anisotropic fluids they exhibit both orientational order and the ability to flow. Individual mesophases are shown schematically in **Figure 5**. In the nematic liquid crystal phase the molecular long axes are aligned in a common direction i.e. along the director, while in the smectic phase the molecules show a degree of translational order and are arranged in layers or planes.

Such supramolecular LC systems were first introduced in 1990 by Lehn et al.⁸ using triple H-bonding based on tartaric acid derivatives containing uracil and 2,6-diacylaminopyridine, and by Kato and Fréchet¹⁹ using polyacrylic acid derivative and a *trans*-stilbazole ester. The enhancement of the LC phase is due to the formation of an elongated mesogenic unit involving a H-bonded moiety. Using a single H-bond between carboxyl and pyridyl functional groups Griffin et al.²⁰ prepared main-chain liquid crystals. In these systems, the individual units are not liquid crystalline, and the rigid mesogens arise as a result of the formation of the H-bond. Since 1990, however, a wide variety of

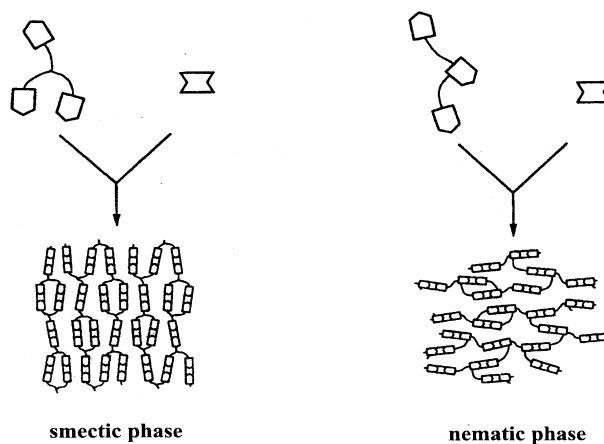

Figure 5: Schematic representation of nematic and smectic mesophases of supramolecular liquid crystalline polymers

Slika 5: Shematska predstavitev nematične in smektične mezofaze supramolekularnih tekočerkristaliničnih polimerov

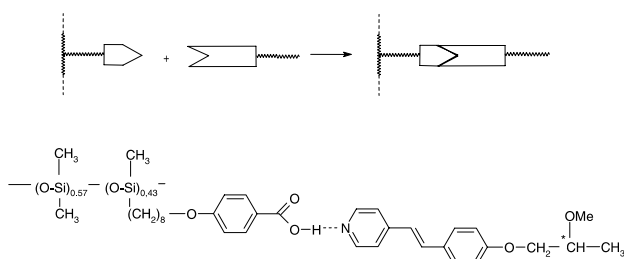

Figure 6: Preparation of supramolecular side-chain liquid crystalline polymers via self-assembly of a mesogenic low molar mass compound and a pendant binding site on the polymer backbone²²

Slika 6: Priprava supramolekularnih strankoverižnih tekočokristaliničnih polimerov iz mezogene nizko molekularne spojine in komplementarne stranske skupine polimerne verige²²

polymeric complexes of main-chain, side-chain, combined, and network structures have been prepared by the formation of a single or multiple hydrogen bonds^{11,13,17,18}.

4 SUPRAMOLECULAR HYDROGEN-BONDED SIDE-CHAIN LIQUID CRYSTALLINE POLYMERS

In contrast to main-chain supramolecular LC polymers, where self-assembled bifunctional monomeric units with two complementary groups (proton donor and proton acceptor) are incorporated into the polymer backbone, the mesogens in side-chain supramolecular LC polymers are attached onto the polymer backbone directly (**Figure 3**) or via a flexible spacer. Consequently, it is possible to prepare LC polymers by noncovalent interactions from amorphous linear

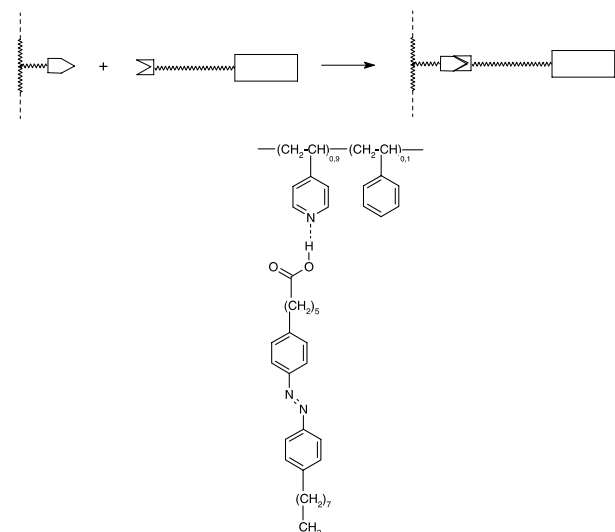

Figure 7: Preparation of supramolecular side-chain liquid crystalline polymers by binding the side chain with the mesogenic unit to the polymer backbone via an H-bonded connector²³

Slika 7: Priprava supramolekularnih strankoverižnih tekočokristaliničnih polimerov z vezavo stranske skupine z mezogeno enoto na polimerno verigo preko strukturne enote, povezane z vodikovo vezjo²³

polymers. Typical examples are polyacrylate, polymethacrylate, and polysiloxane based side-chain LC (SCLC) polymers^{18,21}.

Various synthetic strategies are used for the preparation of supramolecular hydrogen-bonded SCLC polymers. (i) A mesogenic polymer structure can be formed between a mesogenic low molar mass compound and a pendant binding site on the polymer backbone (**Figure 6**)²². (ii) The side chain with the mesogenic unit can be bound to the polymer backbone through an H-bonded connector (**Figure 7**)²³. In both cases, a flexible spacer decouples the motion of the polymer main chain from the motion of the anisotropically oriented mesogenic side chain. (iii) The third strategy involves the self-assembly of a small rigid molecule with an aliphatic tail and a complementary unit in the polymer backbone without the presence of a flexible spacer (**Figure 8**). In some cases, the aliphatic tail stimulates lateral interactions between the mesogens formed and, consequently, enhances liquid-crystallinity. The first example of this approach was shown by Kato et al. using polyamides and benzoic acid derivatives [polyamides with a 2,6-bis(amino)pyridine moiety as proton acceptors, and 4-(alkoxy)benzoic acids and 4-(4'-(octyloxy)phenyl)benzoic acid as proton donors]^{24,25}. In our laboratory, we also prepared this type of SCLC polymer using polyurethane with a pyridyl unit as a part of the polymer main chain. Furthermore, we used a new strategy for the preparation of SCLC (iv)

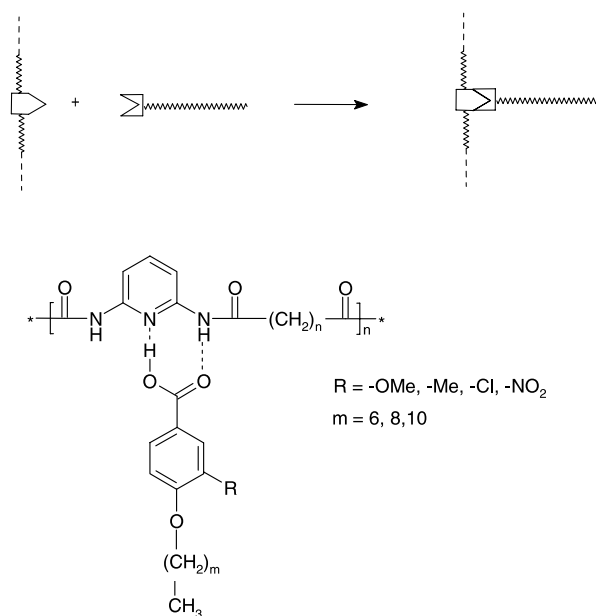

Figure 8: Preparation of supramolecular side-chain liquid crystalline polymers via self-assembly of a small rigid molecule with an aliphatic tail to a complementary unit in the polymer backbone without the presence of a flexible spacer²⁴

Slika 8: Priprava supramolekularnih strankoverižnih tekočokristaliničnih polimerov brez gibljive stranske verige: povezava majhne toge molekule z alifatskim repom in komplementarne enote v polimerni verigi²⁴

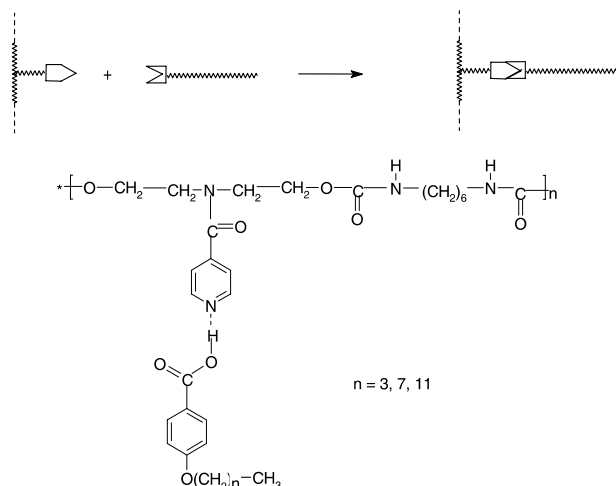

Figure 9: Preparation of supramolecular side-chain liquid crystalline polymers via self-assembly of a small rigid molecule with aliphatic tail to a pendant binding site on the polymer backbone²⁹

Slika 9: Priprava supramolekularnih strankoverižnih tekočokristaliničnih polimerov brez gibljive stranske verige: povezava majhne toge molekule z alifatskim repom in komplementarne stranske skupine polimerne verige²⁹

involving the self-assembly of small rigid molecules with aliphatic tails and complementary units on pendant binding sites on the polymer backbone (**Figure 9**). Thus, we first prepared novel supramolecular SCLC complexes consisting of a polyurethane backbone with pendant pyridyl units (introduced by N,N-bis(2-hydroxyethyl)isonicotinamide) and 4-alkoxybenzoic acids^{26–29}.

For this system, we studied the structure-stability relationship of the length of the terminal alkoxy group (dodecyloxy, octyloxy and butyloxy) of 4-alkoxybenzoic acids and the substituent effect of nitro (NO₂) group in the *meta* position of the aromatic core of 4-dodecyloxybenzoic acid (DOBA). The liquid crystalline behavior was studied by differential scanning calorimetry (DSC), polarizing optical microscopy (POM) and X-ray diffractometry (XRD), whereas hydrogen bond formation between complementary units was investigated by Fourier transform infrared (FTIR) spectroscopy. The polyurethane SCLC complexes with DOBA were formed up to a 0.7 molar ratio of the acid versus the polyurethane repeat unit and showed a highly ordered smectic phase and a nematic phase. However, the stability of the SCLC complexes with 4-alkoxybenzoic acids and shorter alkyl tails, namely 4-octyloxy (OOBA) and 4-butyloxybenzoic (BOBA) acids, decreased and phase separation occurred at lower acid/polymer repeat unit molar ratios: at 0.4 for the OOBA LC complex and at 0.2 for the BOBA amorphous complex. Obviously, the length of the alkoxy group plays an important role in the stabilization of supramolecular polyurethane complexes. Specifically, stability is enhanced with increasing numbers of methylene groups in the aliphatic tail thus indicating that the lateral attractive van der Waals interaction between the methylene groups induces mesogenic properties,

facilitates lamellar packing and, consequently, promotes the formation of a more stable supramolecular system^{28,29}.

The substituent effect on the aromatic ring of the DOBA was investigated using nonmesogenic 3-nitro-4-dodecyloxybenzoic acid (NO₂-DOBA). However, though the electron-withdrawing nitro substituent enhances the acidity of the carboxylic acid group and was also expected to promote the blending of the two components by dipole-dipole interaction between the aromatic rings, a phase separation occurred upon mixing the two components. The lateral side-chain ordering was probably prevented due to the steric hindrance effect of the large nitro group and, consequently, no stable mesomorphic behavior was observed²⁸.

5 APPLICATION OF SUPRAMOLECULAR POLYMERS

In the last three years, the number of literature reports regarding the preparation, characterization and, even more recently, application of supramolecular polymers, has grown strongly. Therefore, it is increasingly apparent that this field is opening up new perspectives and paths to new materials. The advantages of supramolecular polymers over conventional ones are their dynamic assembly and disassembly, which is important in processes such as mobility, chemical transport and structural integrity, and quick responses to external stimuli and different environments³⁰. A brief description of several of these applications is given below.

Impressive achievements in the field of supramolecular materials have been reported for one-dimensional supramolecular fibers employing various kinds of noncovalent interactions to mimic biological structures³¹. Supramolecular polymers with controlled nanostructures have been prepared using diverse approaches. For example, a template (a supramolecular discotic LC polymer) containing ordered hexagonal columnar channels was formed first, and then, after cross-linking of the polymer matrix, the soluble template was removed thus creating a nanoporous material³².

A very recently reported technological application is the preparation of noncovalently functionalized dendrimers for use as recyclable catalysts³³. The concept of supramolecular anchoring of a catalyst to a soluble dendrimer support, *i.e.* urea adamantyl poly(propylene imine), by ionic interactions in combination with multiple hydrogen bonds using well defined binding sites was used to prepare a recyclable homogeneous supramolecular catalyst. Such a catalyst was used in the palladium-catalyzed allylic amination reaction in a batch process as well as in a continuous-flow membrane reactor. The supramolecular catalyst showed the same activity and selectivity as its unbound monomeric analogue.

6 CONCLUSION AND OUTLOOK

The use of intermolecular noncovalent interactions for the preparation of supramolecular polymers has been shown to be a versatile approach to the design of novel polymeric materials. Due to the reversibility of noncovalent interactions these supramolecular polymers are dynamic materials, capable of rearranging their structural patterns, and thus have a major advantage over conventional covalent polymers. Many diverse applications are envisaged for these kinds of materials including smart materials, self-healing materials, and functional materials with integrated dynamic functions, such as photo and electric properties, molecular sensing, molecular information, or catalytic activities.

The basic research that started as a scientific challenge roughly 10 years ago has become a technological reality today – materials are now being made of supramolecular polymers. In conclusion, it can be said that research on supramolecular polymers has paved the way for new high-tech materials and their applications to meet the demands of the 21st century.

ACKNOWLEDGEMENT

This research was supported by the Ministry of Education, Science and Sport of the Republic of Slovenia (Program P0-514-104).

8 REFERENCES

- ¹ H.-G. Elias, An introduction to polymer science, VCH, Weinheim 1997, 4
- ² A. Cifferi, in: Supramolecular Polymers, A. Cifferi, Ed., Marcel Decker, New York 2000, 1
- ³ J. M. Lehn, in: Supramolecular Polymers, A. Cifferi, Ed., Marcel Decker, New York 2000, 615
- ⁴ V. Abetz, in: Supramolecular Polymers, A. Cifferi, Ed., Marcel Decker, New York 2000, 215
- ⁵ S. I. Stupp, M. Keser, G. N. Tew, Polymer, 39 (1998), 4505
- ⁶ J. M. Lehn, Supramolecular Chemistry: Concept and Perspectives, VCH Weinheim, 1995
- ⁷ J. M. Lehn, Angew. Chem. Int. Edit., 29 (1990), 1304
- ⁸ C. Fouquey, J. M. Lehn, A.-M. Levelut, Adv. Mater., 2 (1990), 254
- ⁹ A. Cifferi, Macromol. Rapid Comm., 23 (2002), 511
- ¹⁰ L. Brunsveld, B. J. B. Folmer, E. W. Meijer, MRS Bull., 25 (2000), 49
- ¹¹ L. Brunsveld, B. J. B. Folmer, E. W. Meijer, R. P. Sibejsma, Chem. Rev., 101 (2001), 4071
- ¹² P. S. Corbin, S. C. Zimmerman, in: Supramolecular Polymers, A. Cifferi, Ed., Marcel Decker, New York, 2000, 147
- ¹³ D. C. Sherrington, K. A. Taskinen, Chem. Soc. Rev., 30 (2001), 83
- ¹⁴ R. P. Sibejsma, F. H. Beijer, L. Brunsveld, B. J. B. Folmer, J. H. K. K. Hirschberg, R. F. M. Lange, J. K. L. Lowe, E. W. Meijer, Science, 278 (1997), 1601
- ¹⁵ R. F. M. Lange, M. Van Gorp, E. W. Meijer, J. Polym. Sci.: Polym. Chem., 37 (1999), 3657
- ¹⁶ C. T. Imrie, TRIP, 3 (1995), 22
- ¹⁷ T. Kato, N. Mizoshita, K. Kanie, Macromol. Rapid Comm., 22 (2001), 797
- ¹⁸ T. Kato, Struct. Bond., 96 (2000), 95
- ¹⁹ T. Kato, J. M. J. Fréchet, Macromolecules, 22 (1989), 3818
- ²⁰ C. Alexander, C. P. Janwala, C. M. Lee, A. C. Griffin, Macromol. Symp., 77 (1994), 283
- ²¹ T. Kato, J. M. J. Fréchet, Macromol. Symp., 98 (1995), 311
- ²² U. Kumar, Angew. Chem., Int. Edit., 31 (1992), 1531
- ²³ T. Kato, N. Hirota, A. Fujishima, J. M. J. Fréchet, J. Polym. Sci., Part A: Polym. Chem., 34 (1996), 57
- ²⁴ T. Kato, Y. Kubota, T. Uryu, S. Ujiie, Angew. Chem. Int. Edit., 36 (1997), 1617
- ²⁵ O. Ihata, H. Yokota, K. Kanie, S. Ujiie, T. Kato, Liq. Cryst. 27 (2000), 69
- ²⁶ G. Ambrožič, M. Žigon, Macromol. Rapid Comm., 21 (2000), 53
- ²⁷ G. Ambrožič, M. Žigon, Mater. technol., 34 (2000), 279
- ²⁸ G. Ambrožič, J. Mavri, M. Žigon, Macromol. Chem. Phys., 203 (2002), 439
- ²⁹ G. Ambrožič, Ph.D. Thesis, University of Ljubljana, 2002
- ³⁰ Science, thematic number devoted to Supramolecular Chemistry and Self-Assembly, 295 (2002), 2395-2421
- ³¹ J. D. Hartgerink, E. R. Zuberev, S. I. Stupp, Curr. Opin. Solid St. Mater. Sci., 5 (2001), 355
- ³² H.-K. Lee, H. Lee, Y. H. Ko, Y. J. Chang, N.-K. Oh, W.-C. Zin, K. Kim, Angew. Chem. Int. Edit., 40 (2001), 2669
- ³³ D. de Groot, B. F. M. de Waal, J. N. H. Reek, A. P. H. J. Schenning, P. C. J. Kamer, E. W. Meijer, P. W. N. M. van Leeuwen, J. Am. Chem. Soc., 123 (2001), 8453